



Leica M525 OH4

The Premium Surgical Microscope Solution for Precision Neurosurgery

Living up to Life

Leica
MICROSYSTEMS

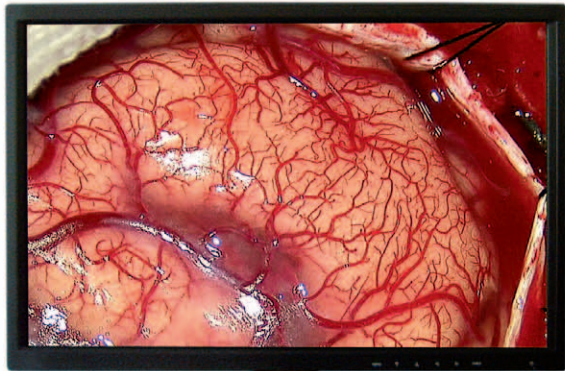

Leica



a M525 OH4

Leica Microsystems stands for excellence in optics. Outstanding contrast, brilliance, sharpness, resolution, color fidelity, and precision are hallmarks of Leica surgical microscopes. The Leica OH4 stand not only complements the Leica M525 optics, but also improves the overall microsurgical experience with superior movement, innovative illumination, and user-friendly features.

Designed and manufactured using superior materials and the highest quality standards, the premium Leica M525 OH4 is built for long service life and outstanding reliability. The Leica M525 OH4 fulfills Leica's vision of providing the best viewing conditions and the greatest maneuverability to enable successful surgery.

Optical Excellence

By integrating new glass, coatings, and design parameters, Leica's OptiChrome™ technology delivers the extra working distance, depth of focus, and light intensity needed for precision microsurgery. It forms the basis for the world's most advanced optical system. Leica M525 optics deliver the following outstanding benefits:

- **Longer** 32% extended working distance to 470 mm
- **Deeper** 30% increased depth of focus at same magnification
- **Brighter** 30% more light intensity
- **Sharper** Higher contrast and crisper, sharper images
- **Smarter** Autoliris™ magnification-controlled illumination



Advanced Illumination

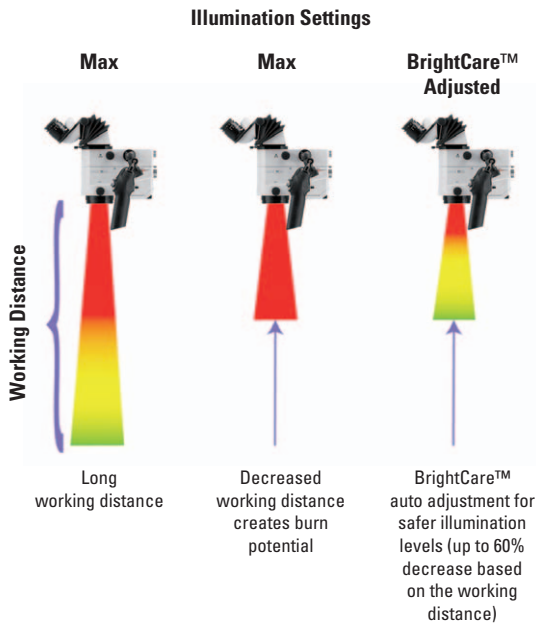

Illumination in an instant, always

The Leica M525 OH4 features two completely independent 300W xenon arc-lamp illumination systems. The second system automatically activates in the event of lamp failure in the primary system, which gives the surgeon confidence to know that surgery will not be jeopardized due to lamp failure.

BrightCare™ – Working-distance-controlled illumination

As a microscope's working distance decreases, the intensity of the microscope light (without adjustments) increases. This can pose a risk of tissue burns to patients. Leica Microsystems' BrightCare™ working-distance-controlled light intensity feature addresses this issue to provide more safety for the patient by adjusting light intensity based on the working distance.

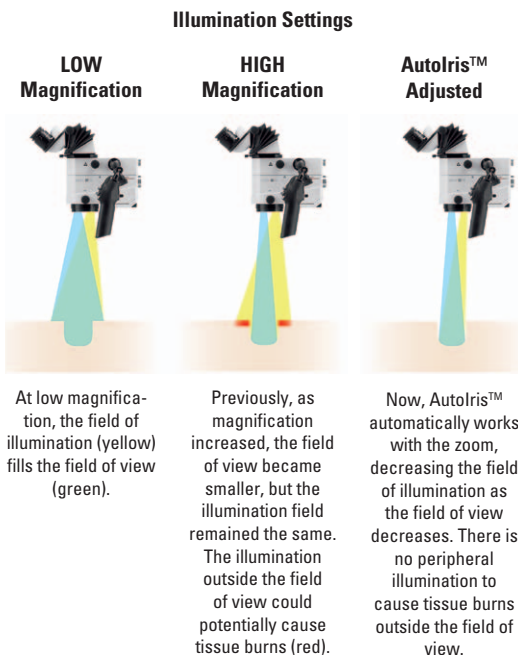

Autolris™ – Magnification-controlled illumination

As magnification increases, the field of view becomes smaller, but the illumination field remains the same. This can potentially cause tissue burns. To provide additional safety for the patient, Leica Microsystems' Autolris™ magnification-controlled illumination diameter auto-matically works with the zoom, providing a field of illumination that is only as wide as the surgeon's field of view.

Compact, yet provides superior reach and ample overhead room

The Leica M525 OH4 provides the highest overhead clearance and the longest reach of any surgical microscope on the market today. Because of the superior reach, the surgeon has the ultimate flexibility to place the microscope wherever it is most beneficial for the surgery.



COMPACT DESIGN



SUPERIOR OVERHEAD REACH

Superior Reach and Height

The Leica M525 OH4 allows perfect positioning for surgery and takes up very little space in the operating room. The Leica M525 OH4 provides superior reach, height, and clearance, which allows it to be conveniently located behind the surgeon in the unique overhead position, or positioned anywhere around or across the operating table.





With its 100° range of lateral movement the surgeon can easily achieve the most challenging side views.

Extraordinary movement

The Leica M525 OH4 offers a greatly expanded range of movement in all dimensions for improved maneuverability. It takes half the force to move the Leica OH4 than other high-end microscopes. The system is vibration-free at all magnification levels. The stand's patented advanced movement system achieves perfect balance in six axes and at all locations and angles of the microscope.

100° range of lateral movement provides the most difficult-to-manuever side views.

150° inclination angle range combined with the most compact microscope provides unmatched comfort, even in difficult positions.

Movement precision – The Leica M525 OH4 has robotic functions on two axes (X/Y) to allow a higher degree of precision movement.



The 150° range of inclination angle combined with a compact microscope provides unmatched ergonomics even in the most difficult positions.



The ergonomically designed mouth switch allows the surgeon to easily position the microscope, hands-free.



The ultra precise pistol grip provides control of the microscope, stand, and IGS and fluorescence functions.

Range of Movement



Fast and Precise Balance

True auto-balance

Leica Microsystems' single button auto-balance-feature saves valuable time. The surgeon activates this feature by simply pushing the auto-balance button, which fully balances all six axes for precise positioning.

Intraoperative re-balance

A microscope frequently needs re-balancing during surgery due to the surgeon's and assistant's need to change positioning. It is easy to re-balance the microscope intraoperatively, even through a sterile drape. Simply push the AC/BC button, conveniently located above the optical head, to quickly and accurately re-balance the microscope in seconds.

Taking control

Fast, precise control over all of the stand's functions, the microscope, and the accessories is vital in the operating room. The Leica M525 OH4 features a touch screen with intuitive graphical user interface.

Leica Microsystems' graphical user interface allows users to conveniently and intuitively control all microscope functions during surgery. Additionally, there are hard keys for illumination control and auto-balancing for added safety.



Intraoperative re-balancing for uninterrupted surgery.

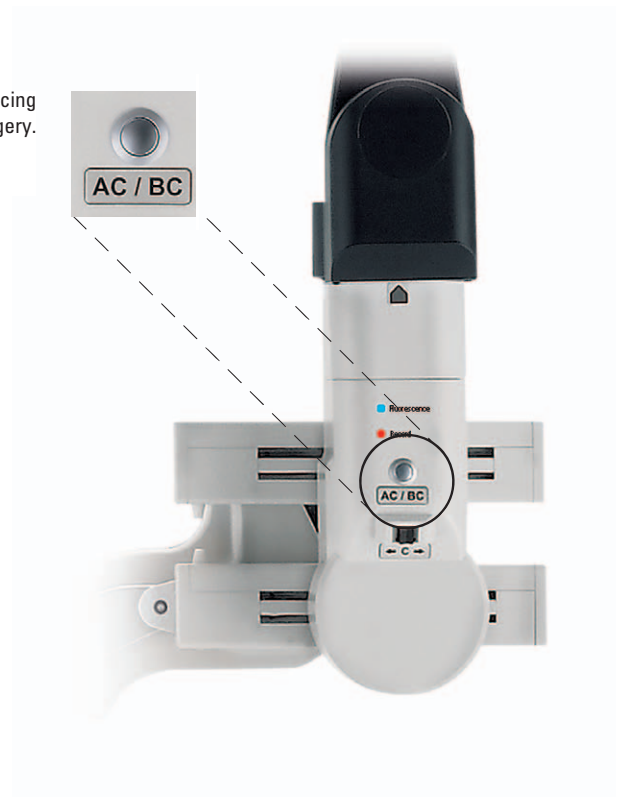

Motorized Inclination and Tilt



The handle's ultra precise joystick allows micrometric movements for tilt and inclination. When preselected, it can also, for example, control the image injection functions.

The Leica M525 OH4 has robotic functions on two axes (X/Y) to further enhance movement precision. The robotic functions can be activated by hand and/or foot controls.

Combined with an IGS computer, the stand's robotic ability allows the microscope to follow the surgeon's hand instruments, thus eliminating the need for the surgeon to take his/her hand away from the surgical site to move the microscope.



Combined with an IGS computer, the Leica OH4 stand's robotic ability allows the microscope to follow the surgical instruments.

Video screen integrated with floor stand

The Leica M525 OH4 features a built-in, movable video screen arm, with three rotation axes and an inclination axis to best position the large video flat screen (optional) into the perfect position for all viewers. Also, all functions of the integrated video recording system are conveniently and directly controlled via the large video screen (using a keyboard, touch pad or touch screen option).



Full image coverage on a 24" HD flat screen and wireless video transfer to the surgeon's Apple® device (optional).



Wireless transfer of high-quality HD videos and still images of surgical cases to the Apple® iPhone, iPod Touch or iPad

Med X Mobile, available at the Apple® App Store, allows a surgeon to wirelessly transfer surgical videos and stills directly from the Med X Change HDMD™ recording unit to the surgeon's Apple® iPhone, iPod Touch or iPad immediately upon procedure completion. This new technology offers surgeons and staff yet another method to transport, view, and share stunning, high-quality content.



Integrated Digital Video



Leica MDRS4 medical digital recording system or HDMD® high-definition video system

Ready for future imaging technologies

The selection of video options continually changes as imaging technology evolves. The Leica M525 OH4 is an open architecture system that allows the surgeon to upgrade components as new video innovations become available. The Leica MDRS4 or the Med X Change HDMD® high-definition digital recording systems are integrated with the Leica M525 OH4 floor stand for convenience and easy accessibility.

Wide choice of Leica Video Adapters

All Leica video adapters offer an intra operative fine focus to adjust the video focus. This enables the surgeon to always achieve crisp and clear focus quality in documentation. For a smooth surgical workflow, the surgeon can also choose between manual or remote control. The remote control can be used sterile (with a sterile cover) or unsterile by any person in the OR. Finally, the c-mount interface allows the connection of a 1/2", 1/3", and HD camera.

The **Leica Zoom Video Adapter** (top left) allows focus and magnification adjustments independently of the surgeon's view.

The **Leica Dual Video Adapter** (top right) for vascular fluorescence cases is NIR optimized with fine focus and remote control.

The **Manual and Remote Video Adapters** (bottom left and right) both have a fine focus. Also, the remote control allows the Remote Video Adapter to be operated from any position and in any situation in the OR.



OpenArchitecture™

OpenArchitecture™ for IGS integration

The Leica DI C500 allows the surgeon to input data from any external source such as MRI, CT, IGS, and endoscopes. With an IGS computer the CT or MRI can be fully correlated to the image in either eyepiece. The fully correlated image can be laid over the actual image or a shutter can be used, which displays the actual image in one eyepiece and the fully correlated image in the other eyepiece.

In combination with the tool tracking capabilities of an IGS system the optical axis and focal plane of the microscope follows the tip of a navigated tool in any lateral direction.



The Leica DI C500 Dual Imaging Module handles more data formats than ever before.

Neuro-endoscopy images

Non-correlated images, such as endoscope images, can be projected with the highest resolution and contrast available. With the Leica DI C500, the surgeon can view the endoscopy image in whichever microscope eyepiece he or she chooses.

Tool tracking

In combination with the tool tracking capabilities of an IGS system, the Leica M525 OH4 microscope can track an instrument in the X,Y, and focus axis. Move the instrument and the microscope follows without the surgeon touching the handle grips.

Integrated Fluorescence

Neurovascular fluorescence

The study of fluorescence microscopy has a long tradition at Leica Microsystems, dating back to the beginning of the 20th century. An indispensable component of biological research, fluorescence science is now integrated with the technology of the surgical microscope to provide state-of-the-art neuro-vascular fluorescence.

Leica FL400*

The Leica FL400 enables fluorescence-guided tumor resection.

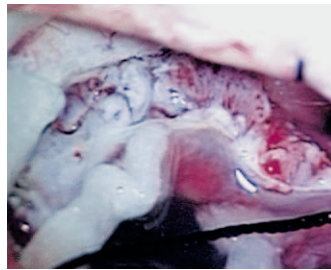

Malignant glioma, white light mode

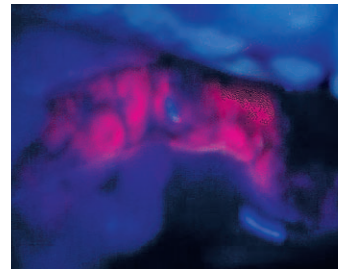

Malignant glioma, blue light mode

Leica FL800*

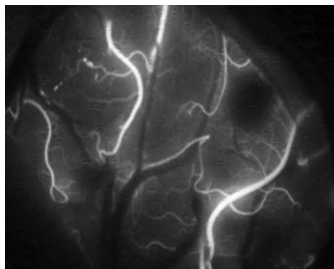

ICG injection after 2 seconds:
Arterial view

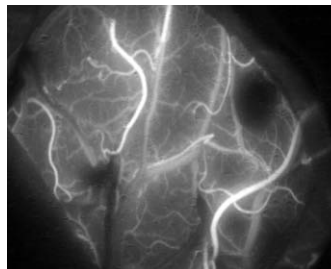

ICG injection after 5 seconds:
Capillary view

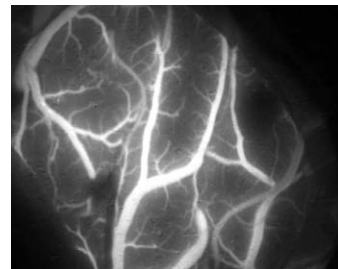

ICG injection after 9 seconds:
Venous view

The Leica FL800 allows surgeons to determine the patency of blood flow through vessels during surgery.

* Please check the status of Leica FL400 and Leica FL800 regulatory approval with your local Leica Microsystems representative.

Superior Reliability and Safety

Trusted reliability

Leica Microsystems utilizes superior materials and design technologies, and manufactures to the highest quality standards for long service life and outstanding reliability. The Leica M525 OH4's full metal construction is designed to withstand intensive use in the operating room, remain precise throughout its life, and maintain its value. Smart engineering and special vibration-dissipating materials further support the stable, extra long swing arm. The Leica OH series has proven to be consistently reliable.

Full metal construction

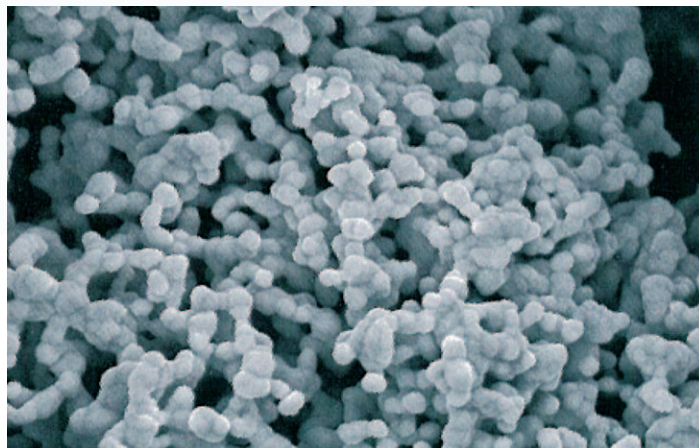

Typical structure of a metal powder (Ag) produced via inert gas condensation (nano powder).

AgProtect™: anti-microbial coating for added safety

Leica Microsystems' antimicrobial nano silver coating, AgProtect™, provides outstanding protection to microscope users by reducing exposure to surface pathogens. AgProtect™ covers the microscope's outside surface and protects the operator and other individuals in the work area by penetrating the membranes of microbes to prevent replication. Leica Microsystems develops instruments with added safety for its customers, medical teams, and their patients through AgProtect™.

Technical Specifications

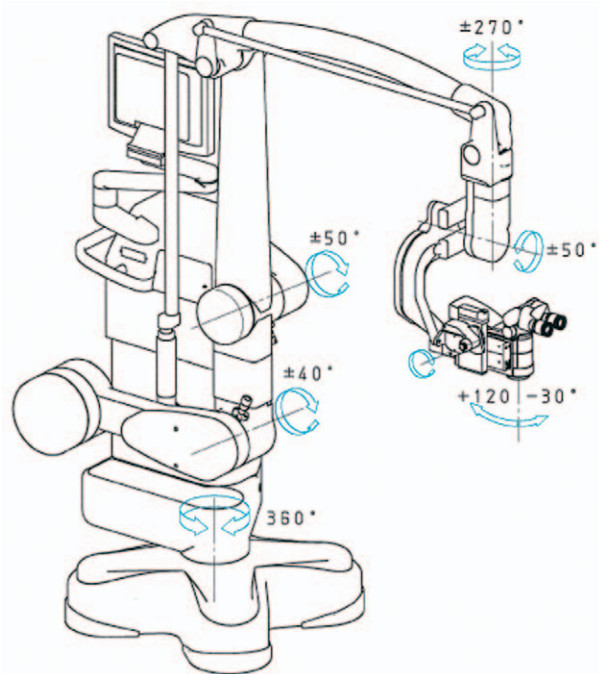
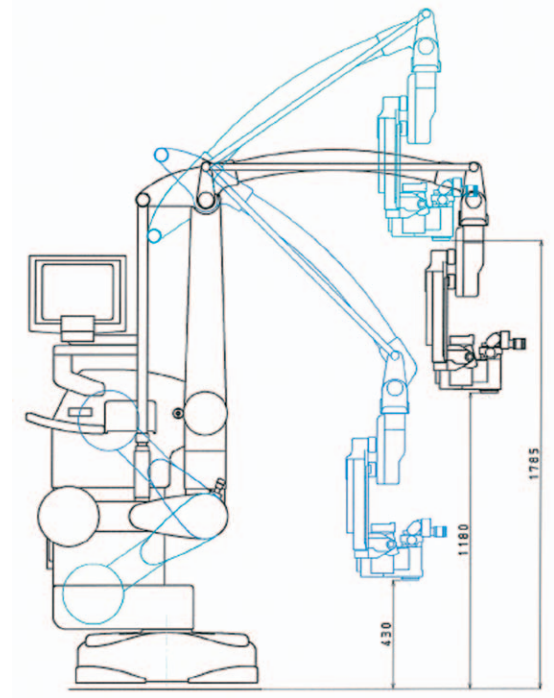
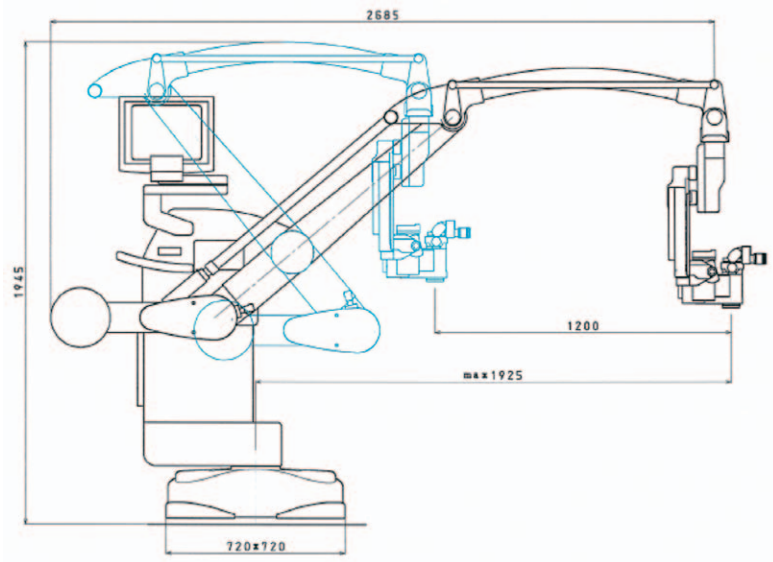

Dimensions in mm

ELECTRICAL DATA

Power connection	1600 VA 50/60 Hz 100 V (+10%/-15%), 120 V (+10%/-15%), 220 V (+10%/-15%), 240 V (+10%/-15%)
Safety class	Class 1

LEICA M525 MICROSCOPE

Magnification	6:1 zoom, motorized
Focus	Motorized via multifocal lens, with manual adjustment
Eyepieces	Widefield eyepieces for eyeglass wearers 10× and 12.5×, dioptric setting ±5 with adjustable eye cup
Objective	Multifocal lens, 207 mm to 470 mm variable working distance through motorized lens, continuously adjustable, with manual override Optional WD extender lens (not for IGS applications)
Illumination	Continuously adjustable illumination field diameter with Gauss-shaped light distribution; continuously adjustable brightness at a constant color temperature
Main light source	High-performance 300 Watt xenon arc-lamp through fiber optic
Emergency lamp	300 Watt xenon arc-lamp on a separate electrical system
Autolris™	Built-in, automatic, zoom-synchronized illumination field diameter, with manual override and reset feature
BrightCare™	Safety technology for the working distance-synchronized light control

OPTICAL DATA

Magnification range	1.2× – 12.8× with 10× eyepiece
Field of view	16.5 mm to 180 mm with 10× eyepiece

MICROSCOPE CARRIER

Rotation of optics	540°
Lateral tilt	50° to left / 50° to right
Inclination tilt	-30° / +120°
XY speed	Zoom-correlated XY speed
Balancing	A, B, C, and D axes are fully automatic, each can be manually balanced
Intraoperative balancing	AC/BC button for automatic intraoperative re-balancing of the A and C axes, and for re-balancing the B and C axes
Brakes	1 brake for A/B axis, 1 brake for C axis
Indicator	LED for fluorescence mode status, LED for video record status

ACCESSORIES

Leica ULT500	180° stereo observer ports with selectable lateral or opposite assistant: Main surgeon and opposite assistant 40% each eyepiece, lateral assistant / video 20% each eyepiece / beam path
Second observer	Dual stereo attachment: 50% each eyepiece
Beam splitter	50% / 50%, 70% / 30%
Binocular tube	Variable angle 0° – 180° Variable angle 30° – 150°
Video adapter	Leica Manual Video Adapter (MVA), 55 mm, 70 mm, 107 mm focal length, c-mount, with fine focus Leica Remote Video Adapter (RVA), 55mm, 70 mm, 107 mm focal length, c-mount, with fine focus Leica Zoom Video Adapter (ZVA), 3:1 zoom, 35 mm to 100 mm focal length, c-mount, with fine focus Leica NIR Dual Video Adapter (DVA), 60.6 mm, 79.5 mm focal length, c-mount, with fine focus
Imaging	Leica DI C500 high resolution true dual imaging color module for correlated and non correlated data display, 1024 × 768 pixel resolution, 256 grey scale
Asepsis	Sterilizable protective glass for the objective; sterilizable components for all drive knobs, commercially available drapes
Laser	Various commercially available lasers and laser shutters can be attached

IGS

IGS interface / compatibility	Open architecture for IGS systems
-------------------------------	-----------------------------------

FLUORESCENCE

Vascular fluorescence	Optional Leica FL800 is available in the USA, EU, and most other countries
Oncological fluorescence	Optional Leica FL400 is available in the EU, and some other countries

Please check the status of regulatory approval with your local Leica Microsystems representative.

Technical Specifications

Leica M525 OH4

LEICA OH4 FLOOR STAND

Type	Floor stand with six electromagnetic brakes
Base	720 mm × 720 mm with four 360° rotatable casters of 130 mm diameter each; one central, single step foot brake
Balancing	One button / two pushes for complete, automatic balancing of stand and optics
Intraoperative re-balancing	AC / BC button for automatic intraoperative re-balancing of the AC axis and the BC axis
Swing arm	Patented advanced movement system for perfect balance in six axes, vibration-dissipating technology
Floor stand control unit	New generation touch panel technology. The latest electronics control for continuous control of all motor functions and the light intensity. Data shown by means of LCD. Built-in BrightCare™ technology for working distance synchronized light control. ISUS™ Intelligent Setup System, menu selection based on unique software for user-specific configuration, with built-in electronic auto-diagnosis and user support. Software-independent hard keys for illumination and auto-balancing. Indicator for main / backup illumination and fluorescence modes. Open architecture for future software developments.
Light source	Dual xenon arc-lamp illumination system and built-in, quick lamp changer
Controls	10-function pistol grips for zoom, focus, all-free release of six brakes, side button for user-defined brakes, motorized lateral tilt and inclination (XY), Leica DI C500 or fluorescence functions. Except for the all-free button, all functions are freely programmable. Mouth switch for releasing the user defined brakes 12-function foot control, hand switch
Integration of documentation	Prepared for integration of video- and digital recording systems. Open architecture
Connectors	Numerous built-in connectors for video, IGS, and control data transfer Internal power 12 VDC, 19 VDC, and AC connections
Carrier for monitor	700 mm long Flexible arm with 4 axes for the rotation and inclination required to carry optional video monitor
Materials	All solid metal construction
Surface coating	Coated with antimicrobial paint (AgProtect™)
Minimal height	In parked position 1945 mm
Range cantilever	Max. 1925 mm
Load	Min. 6.7 kg and max. 12.2 kg of accessories to the microscope
Weight	Approx. 320 kg without load

HD IMAGING

For more information, please refer to your local Leica Microsystems Sales Representative.

AMBIENT CONDITIONS

In use	+10° C to +40° C (+50° F to +104° F), 30% to 95% rel. humidity, 500 mbar to 1060 mbar atmospheric pressure
Storage	-40° C to +70° C (-40° F to +158° F), 10% to 100% rel. humidity, 500 mbar to 1060 mbar atmospheric pressure

LIMITATIONS OF USE

The Leica M525 OH4 surgical microscope may be used only in closed rooms and must be placed on a solid floor.

CONFORMITY

Council Directive 93/42/EEC on Medical Devices (MDD) and its amendments. Classification: Class I, in compliance with Annex IX, rule 1 and rule 12 of the directive. Medical Electrical Equipment, Part 1: General Requirements for Safety IEC 60601-1; EN 60601-1; UL60601-1; CAN/CSA-C22.2 NO. 601.1-M90. Electromagnetic compatibility IEC 60601-1-2; EN 60601-1-2. The Medical Division, within Leica Microsystems (Schweiz) AG, holds the management system certificates for the international standards ISO 9001, ISO 13485, and ISO 14001 relating to quality management, quality assurance and environmental management.



“With the user, for the user”

Leica Microsystems

Leica Microsystems operates globally in four divisions, where we rank with the market leaders.

• Life Science Division

The Leica Microsystems Life Science Division supports the imaging needs of the scientific community with advanced innovation and technical expertise for the visualization, measurement, and analysis of microstructures. Our strong focus on understanding scientific applications puts Leica Microsystems' customers at the leading edge of science.

• Industry Division

The Leica Microsystems Industry Division's focus is to support customers' pursuit of the highest quality end result. Leica Microsystems provide the best and most innovative imaging systems to see, measure, and analyze the microstructures in routine and research industrial applications, materials science, quality control, forensic science investigation, and educational applications.

• Biosystems Division

The Leica Microsystems Biosystems Division brings histopathology labs and researchers the highest-quality, most comprehensive product range. From patient to pathologist, the range includes the ideal product for each histology step and high-productivity workflow solutions for the entire lab. With complete histology systems featuring innovative automation and Novocastra™ reagents, Leica Microsystems creates better patient care through rapid turnaround, diagnostic confidence, and close customer collaboration.

• Medical Division

The Leica Microsystems Medical Division's focus is to partner with and support surgeons and their care of patients with the highest-quality, most innovative surgical microscope technology today and into the future.

The statement by Ernst Leitz in 1907, “with the user, for the user,” describes the fruitful collaboration with end users and driving force of innovation at Leica Microsystems. We have developed five brand values to live up to this tradition: Pioneering, High-end Quality, Team Spirit, Dedication to Science, and Continuous Improvement. For us, living up to these values means: **Living up to Life.**

Active worldwide

Australia:	North Ryde	Tel. +61 2 8870 3500	Fax +61 2 9878 1055
Austria:	Vienna	Tel. +43 1 486 80 50 0	Fax +43 1 486 80 50 30
Belgium:	Groot Bijgaarden	Tel. +32 2 790 98 50	Fax +32 2 790 98 68
Canada:	Concord/Ontario	Tel. +1 800 248 0123	Fax +1 847 405 0164
Denmark:	Ballerup	Tel. +45 4454 0101	Fax +45 4454 0111
France:	Nanterre Cedex	Tel. +33 811 000 664	Fax +33 1 56 05 23 23
Germany:	Wetzlar	Tel. +49 64 41 29 40 00	Fax +49 64 41 29 41 55
Italy:	Milan	Tel. +39 02 574 861	Fax +39 02 574 03392
Japan:	Tokyo	Tel. +81 3 5421 2800	Fax +81 3 5421 2896
Korea:	Seoul	Tel. +82 2 514 65 43	Fax +82 2 514 65 48
Netherlands:	Rijswijk	Tel. +31 70 4132 100	Fax +31 70 4132 109
People's Rep. of China:	Hong Kong	Tel. +852 2564 6699	Fax +852 2564 4163
	Shanghai	Tel. +86 21 6387 6606	Fax +86 21 6387 6698
Portugal:	Lisbon	Tel. +351 21 388 9112	Fax +351 21 385 4668
Singapore		Tel. +65 6779 7823	Fax +65 6773 0628
Spain:	Barcelona	Tel. +34 900 210 992	Fax +34 93 494 95 40
Sweden:	Kista	Tel. +46 8 625 45 45	Fax +46 8 625 45 10
Switzerland:	Heerbrugg	Tel. +41 71 726 34 34	Fax +41 71 726 34 44
United Kingdom:	Milton Keynes	Tel. +44 800 298 2344	Fax +44 190 824 6312
USA:	Buffalo Grove/Illinois	Tel. +1 800 248 0123	Fax +1 847 405 0164

and representatives in more than 100 countries

The Medical Division, within Leica Microsystems (Schweiz) AG, holds the management system certificates for the international standards ISO 9001, ISO 13485, and ISO 14001 relating to quality management, quality assurance and environmental management.

